



Active Thermal Management

The trusted name in thermal protection...

Parts list – before proceeding, check that you have received all of the following:

- (1) control unit
- (2) or (4) (depending on model) 120mm fans
- (2) or (4) finger guards
- (1) power supply
- (1) thermal sensor/probe

System 2 Kit and 2 + 2 Kit Instructions

NOTE: Read these instructions as the System 2 Kit and 2+2 Kit were recently updated.

The Active Thermal Management System 2 and 2 + 2 kits are self-contained ventilating systems for small-to-midsize enclosures with moderate heat loads. The major individual components are the 2-speed control unit, power supply, temperature sensor/probe, and two (2) or four (2+2) 4.7"/120mm fans.

A quick overview of the installation process:

1. The fans are located at the point(s) where heated air is to be exhausted from the enclosure. If desired, 1 or 2 fans can be used to bring room air into the enclosure, while the other 1 or 2 exhaust the heated air. See “Cooling the Mid-size Enclosure” on the Downloads page at activethermal.com for typical fan locations.
2. The control unit is mounted in a convenient location.
3. The thermal sensor is positioned where it will sense air and/or equipment temperatures.
4. The fan, power supply, and thermistor wires are connected to the control unit.
5. The power supply is plugged into a convenient source of 120 volt 60Hz power.
6. The completed installation is tested.

Detailed instructions:

Note: Do not plug the power supply into an outlet until directed to do so.

25570 Rye Canyon Rd.
(661) 294-7999 voice
techinfo@activethermal.com

Valencia, California 91355
(661) 294-1115 fax
www.activethermal.com

Cut a 4 ½” center hole and drill 4 mounting holes for each of the fans per the drawing on page 4. The fans can be mounted either on the inside or outside surface of the enclosure; air moves towards the label side of the fan. If there is any possibility of contact with the fan blades when the system is in use, install the guards supplied to prevent personal injury.

When locating the fans, remember that provision must be made to allow room air to enter the enclosure to replace the hot air being exhausted. Intake locations low in the enclosure are generally preferred; the optimum arrangement is that in which air enters and passes by the heat-generating equipment on its way to the exhaust fans. Avoid locating the inlet too close to the exhaust fans as room air may enter and be immediately exhausted without cooling the enclosure and equipment.

An air inlet improperly located or too small will prevent the System 2 or 2 + 2 from operating efficiently and quietly.

2. Mount the control unit at a convenient location. Plug the 2 or 4 fan wires into the connectors on it. (Any fan can be plugged into any fan connector.)

3. The thermal probe controls the operation of the fans. Locate it where it can sense system heat; usually on top of the hottest component. Hold it in place with the supplied ty-wrap and anchor. Plug the thermal probe into connector TH1.

4. The System 2 or 2 + 2 is powered by a wall-type power supply. Do not plug it into a switched outlet; use an AC outlet which is always on to allow the fans to run after the other equipment has been turned off. If possible, use an outlet on the same circuit that powers the equipment producing the most heat. If this circuit should fail, the ventilation will cease, but the heat source(s) will also turn off. If the System 2 or 2 + 2 is powered from a different circuit, it is possible that the cooling circuit could lose power while the equipment in the enclosure continued to produce heat.

Operational test:

Plug the power supply into a live outlet. Plug the power supply output lead into the female connector attached to the control box. The green LED will light to indicate that power is present. As the temperature at the thermal sensor rises past approximately 85 degrees (F), the fans will begin to turn at a moderate speed and the yellow led will light. Fan speed will increase if the temperature increases 5 degrees. A red LED will then indicate that the fans are turning at full speed.

When the enclosure temperature falls, the fans will slow down, stopping when the temperature falls below approximately 85 degrees Fahrenheit.

- ***Please note: It is common for the fans to remain on continuously in low speed, due to the heat given off by satellite receivers, cable boxes, and PVRs, even when these devices are not in use.***

25570 Rye Canyon Rd.
(661) 294-7999 voice
techinfo@activethermal.com

Valencia, California 91355
(661) 294-1115 fax
www.activethermal.com

WARRANTY

ACTIVE THERMAL MANAGEMENT ("ATM") WARRANTS ALL OF ITS PRODUCTS SOLD AFTER OCTOBER 1, 2017 AGAINST DEFECTS IN MATERIALS AND WORKMANSHIP FOR A PERIOD OF FIVE YEARS. (PRODUCTS SOLD BEFORE THAT DATE ARE WARRANTED FOR A PERIOD OF ONE YEAR.) WE WILL REPAIR OR REPLACE, AT OUR OPTION, ANY ATM PRODUCT WHICH EXHIBITS A DEFECT IN MATERIALS OR WORKMANSHIP IN THAT TIME PERIOD. THE PRODUCT MUST BE PROPERLY PACKAGED AND RETURNED PREPAID WITH AN ATM RETURN AUTHORIZATION NUMBER CLEARLY WRITTEN ON THE OUTSIDE OF THE SHIPPING CARTON AND WITH A COPY OF THE BILL OF SALE OR ATM INVOICE TO VERIFY THE ORIGINAL PURCHASE DATE.

OUR WARRANTY DOES NOT APPLY TO:

- 1. SHIPPING DAMAGE, EITHER CONCEALED OR VISIBLE. CLAIMS MUST BE FILED WITH THE CARRIER.**
- 2. DAMAGE CAUSED BY IMPROPER INSTALLATION OR IMPROPER ELECTRICAL VOLTAGE.**
- 3. ANY PRODUCT WHICH HAS BEEN MODIFIED, UNLESS AUTHORIZED BY ATM.**
- 4. DAMAGE CAUSED BY CORROSION, ABRASION, IMMERSION, OR SEVERE TEMPERATURES.**
- 5. PRODUCTS WHICH HAVE BEEN SUBJECT TO ABUSE, MISUSE, ABNORMAL USAGE, OR ACCIDENT.**
- 6. PRODUCTS PURCHASED FROM UNAUTHORIZED RESELLERS.**

PRODUCTS OR SUBASSEMBLIES WHICH ARE BEYOND REPAIR MAY BE REPLACED WITH REFURBISHED UNITS. REPLACED UNITS OR SUBASSEMBLIES WILL BE WARRANTED FOR THE BALANCE OF THE ORIGINAL WARRANTY PERIOD AND MAY HAVE MINOR COSMETIC BLEMISHES.

THESE WARRANTIES GIVE YOU SPECIFIC LEGAL RIGHTS, AND ARE SUBJECT TO ANY APPLICABLE CONSUMER PROTECTION LEGISLATION. YOU MAY ALSO HAVE ADDITIONAL RIGHTS WHICH VARY FROM STATE TO STATE.

NO OTHER WARRANTIES, EXPRESSED, IMPLIED, OR WRITTEN, SHALL APPLY TO THIS PRODUCT. ATM WILL NOT BE RESPONSIBLE FOR ANY CONSEQUENTIAL OR INCIDENTAL DAMAGES, LOSS OF PROPERTY, REVENUES, OR PROFIT, COST OF REMOVAL, INSTALLATION, OR REINSTALLATION, PERSONAL INJURY, OR FOR ANY BREACH OF WARRANTY, REGARDLESS OF HOW CAUSED.

25570 Rye Canyon Rd.
(661) 294-7999 voice
techinfo@activethermal.com

Valencia, California 91355
(661) 294-1115 fax
www.activethermal.com

ATM System 2 & 2+2 fan mounting details

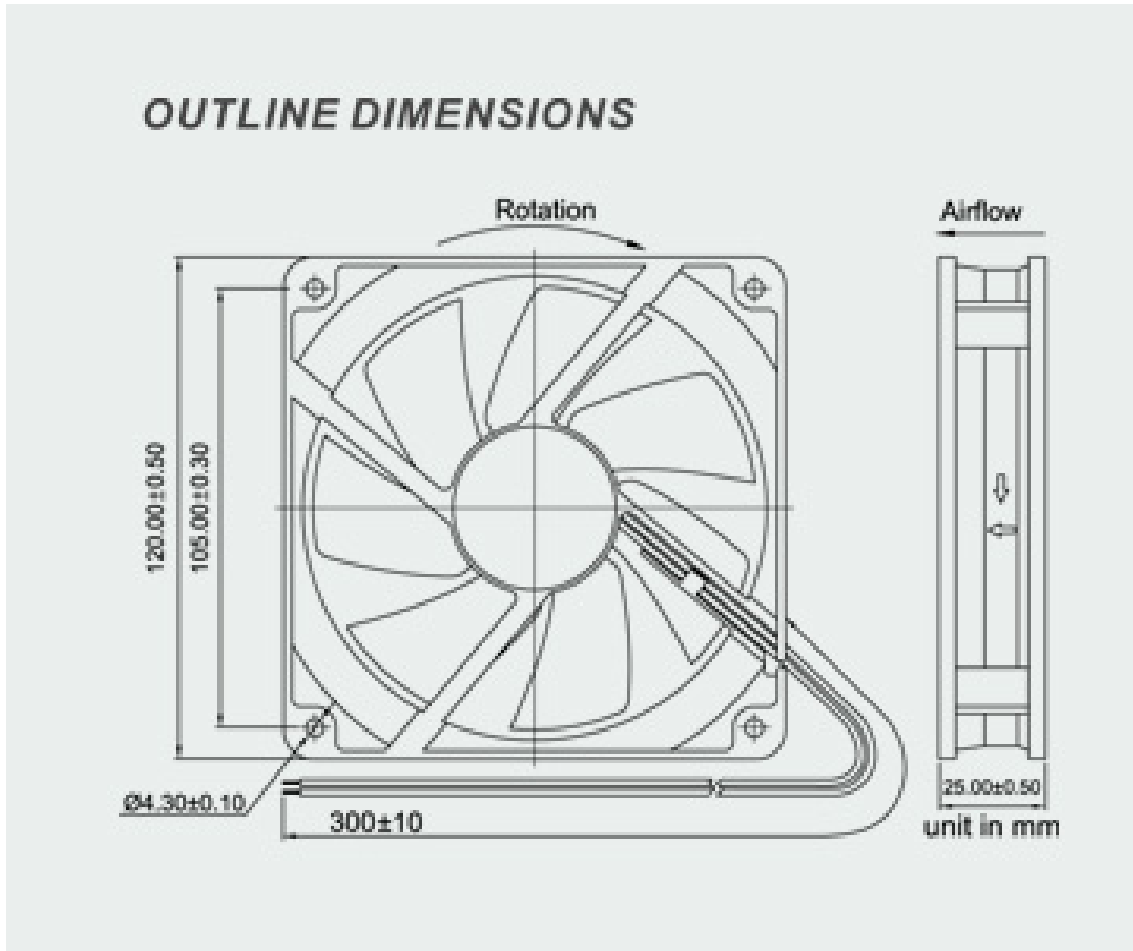

Large center hole -- 4½"/114mm

Corner holes for mounting screws – 3/16"/4.3mm

25570 Rye Canyon Rd.
(661) 294-7999 voice
techinfo@activethermal.com

Valencia, California 91355
(661) 294-1115 fax
www.activethermal.com